

OFD-CI2ELBASE-120-

2 Stage 120° Electric Height Adjustable Base



(-BS) Brushed Silver



3 Memory Controller
with 2 USB Ports

Paint



Brushed Silver

White

Black

Smart L-type Products
Automatic Lifting

Noise Level
50db

Warranty Period
7 years



RoHS

OFD-CI2 ELBASE-120-

2 Stage 120° Electric Height Adjustable Base

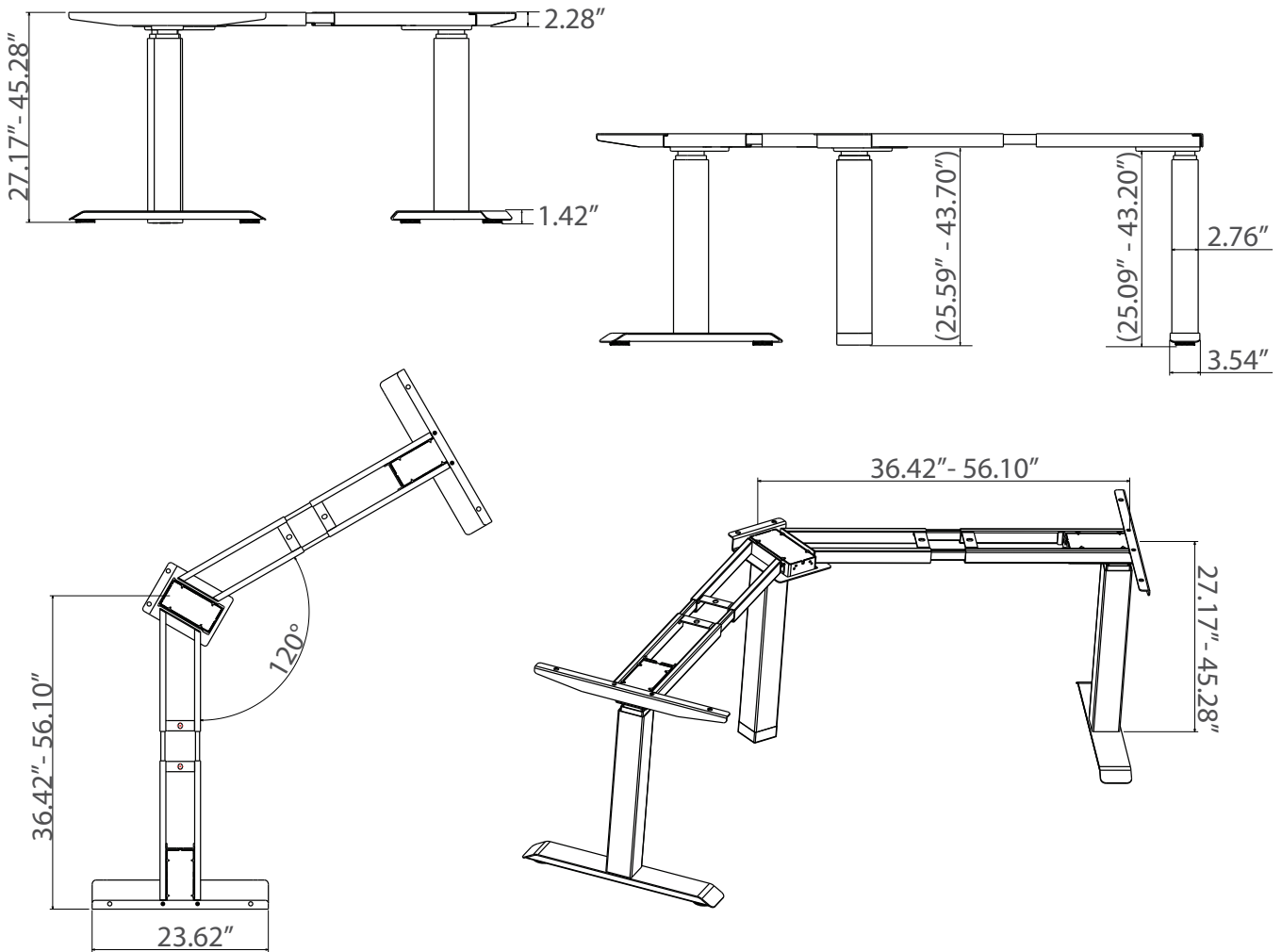

TYPE	DATA
Leg Shape	Square
Frame Height Adjustable Range	27.17" - 45.28" (Top adds 1.1")
Frame Adjustable Range	$W(36.42-56.10")+(36.42-56.10")*D(23.62")$
Foot Length Size	23.62"
Speed	1.26" /second
Maximum Lifting Capacity	330 lbs
Input	100-240V