

# OFD-CI2ELBASE-90-

2 Stage 90° Electric Height Adjustable Base



**7**  
**YEAR**  
**WARRANTY**



**(-BS) Brushed Silver**



**3 Memory Controller  
with 2 USB Ports**

### Paint



**Brushed Silver**

**White**

**Black**

 Smart L-type Products  
Automatic Lifting

 Noise Level  
50db

 Warranty Period  
7 years



**RoHS**

# OFD-CI2ELBASE-90-

2 Stage 90° Electric Height Adjustable Base

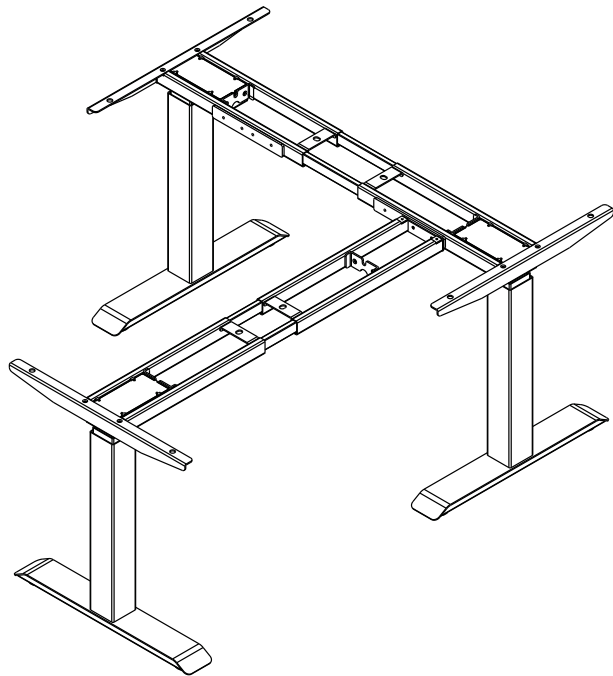
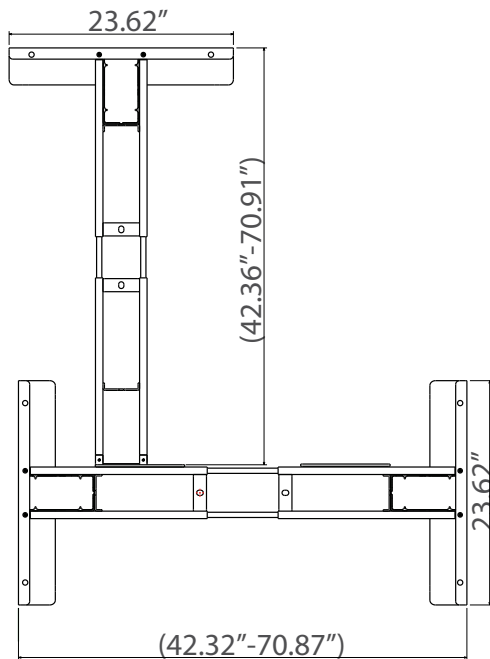
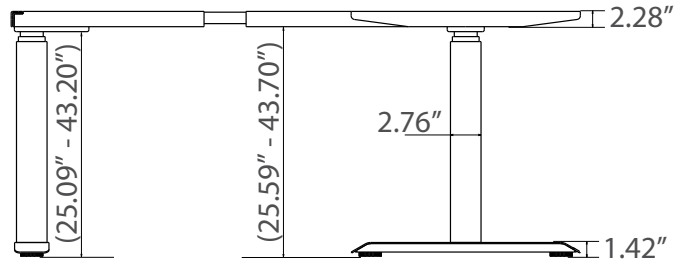
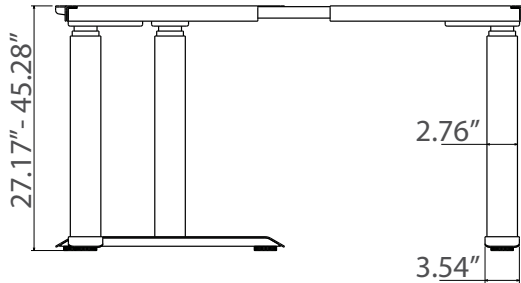

TYPE	DATA
Leg Shape	Square
Frame Height Adjustable Range	27.17" - 45.28" (Top adds 1.1")
Frame Adjustable Range	$W(42.36-70.91")+(42.32-70.87")*D(23.62")$
Foot Length Size	23.62"
Speed	1.26 " /second
Maximum Lifting Capacity	330 lbs
Input	100-240V