

# **OFD-CI2ELBASE-A-** 2 Stage, Dual Motor Electric Height Adjustable Base



(-BS) Brushed Silver



3 Memory Controller  
with 2 USB Ports

(Optional Casters)



### Paint



Brushed Silver

White

Black



Smart L-type Products  
Automatic Lifting



Noise Level  
45db



Warranty Period  
7 years



RoHS

# OFD-CI2ELBASE-A-

2 Stage, Dual Motor Electric Height Adjustable Base

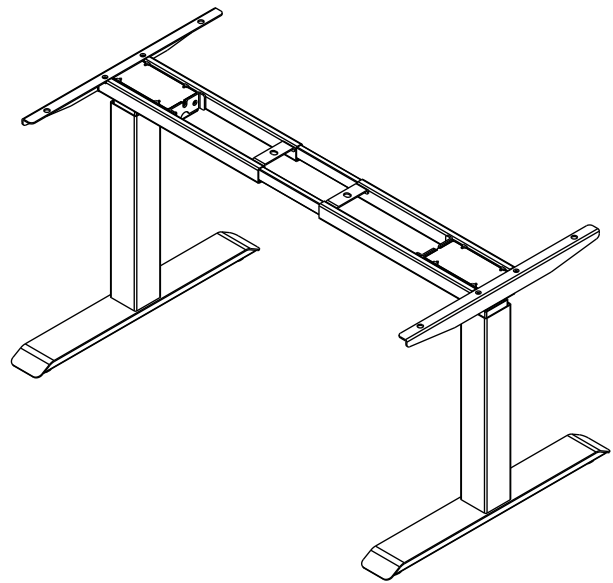
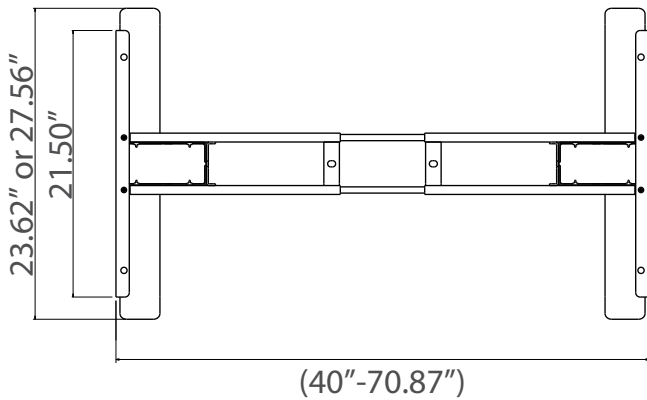
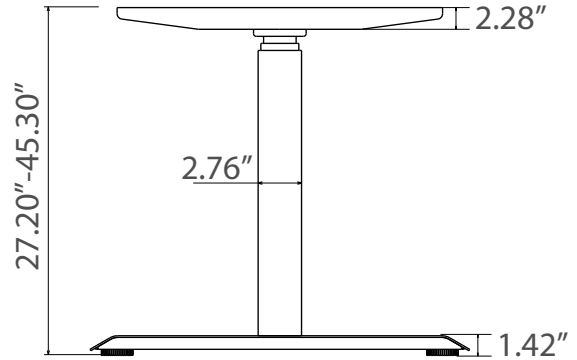
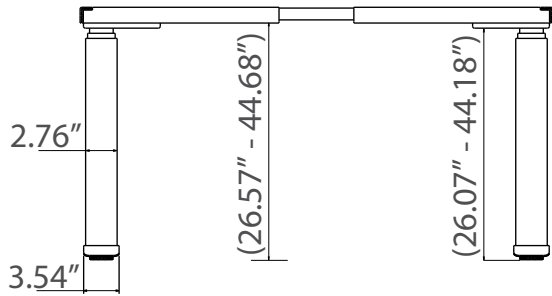

TYPE	DATA
Leg Shape	Square
Frame Height Adjustable Range	27.20" - 45.30" (Top adds 1.1")
Frame Adjustable Range	W(40-70.87")*D(21.5")
Foot Length Size (2 Options)	23.62" or 27.56"
Speed	1.6" /second
Maximum Lifting Capacity	264 lbs
Input	100-240V