

OFD-C13ELBASE-90-

3 Stage 90° Electric Height Adjustable Base

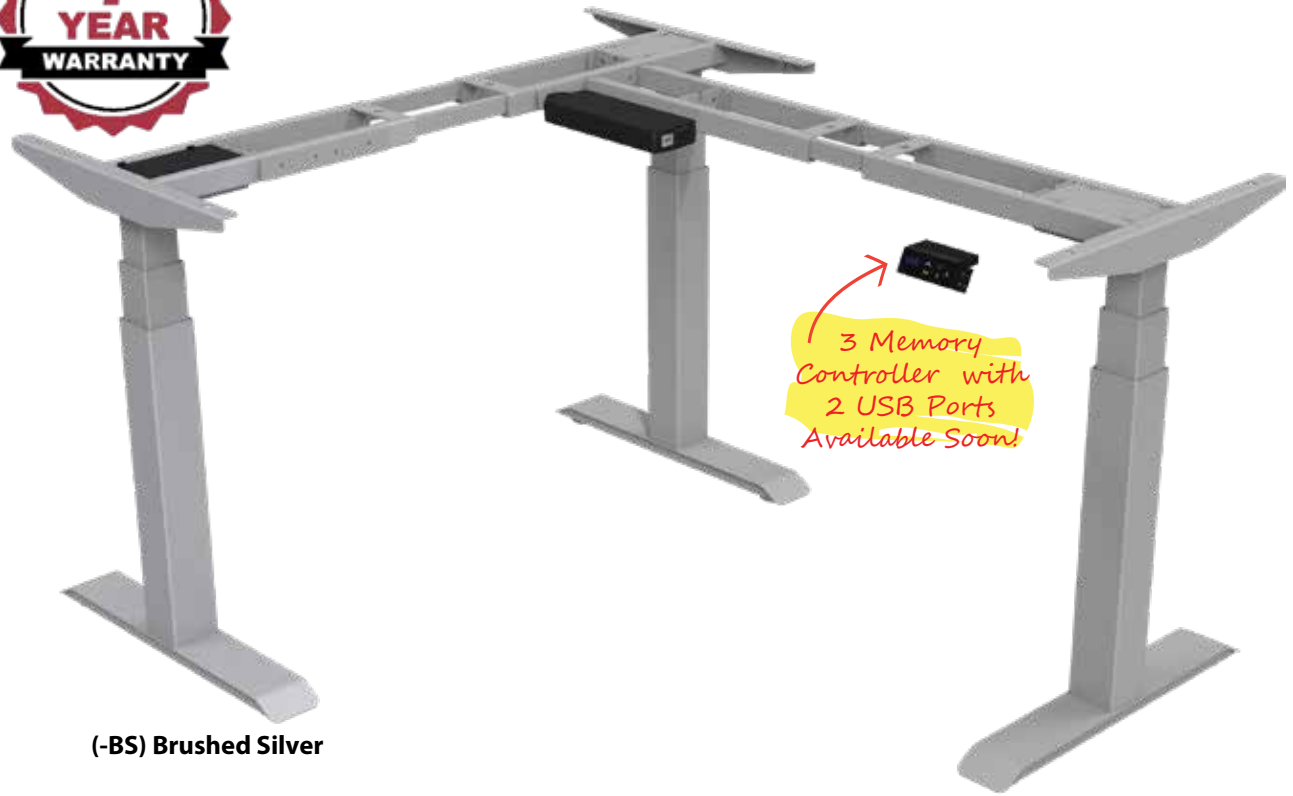

7
YEAR
WARRANTY



3 Memory
Controller with
2 USB Ports
Available Soon!

(-BS) Brushed Silver



4 Memory Controller

Paint



Brushed Silver

White

Black

Smart L-type Products
Automatic Lifting

Noise Level
45db

Warranty Period
7 years



RoHS

OFD-CI3ELBASE-90-

3 Stage 90° Electric Height Adjustable Base

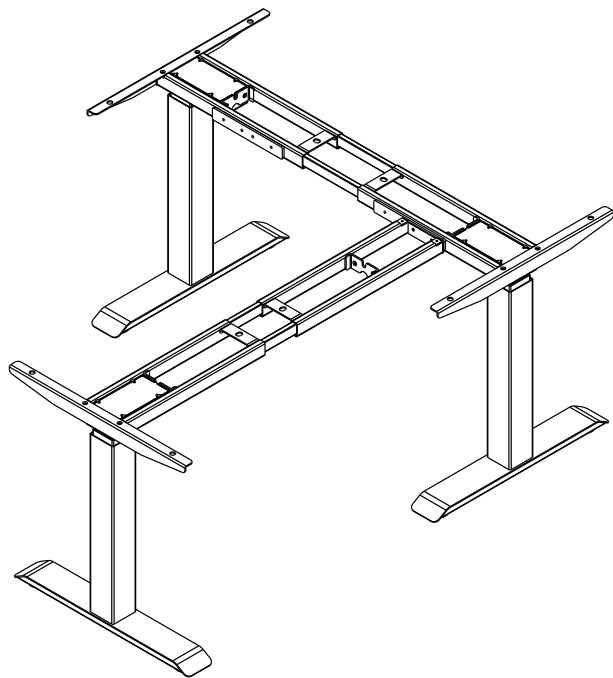
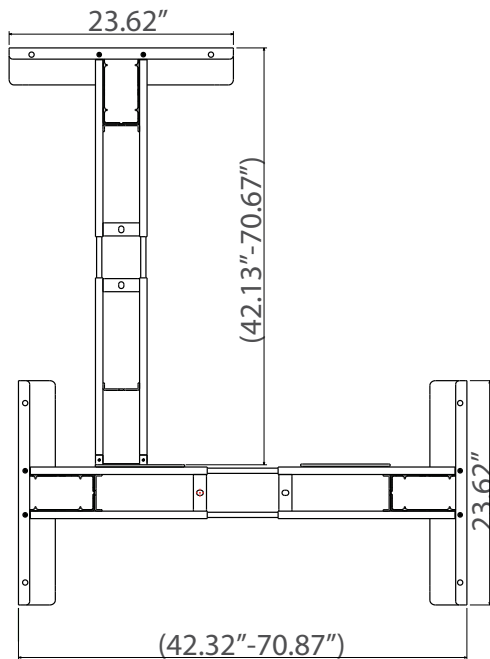
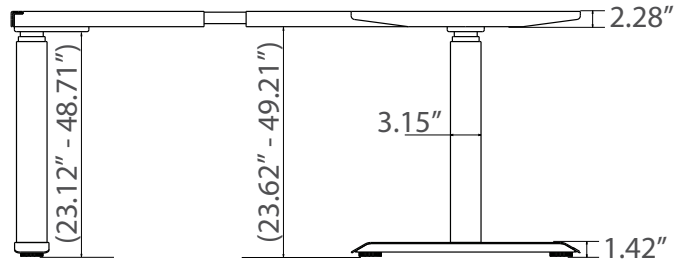
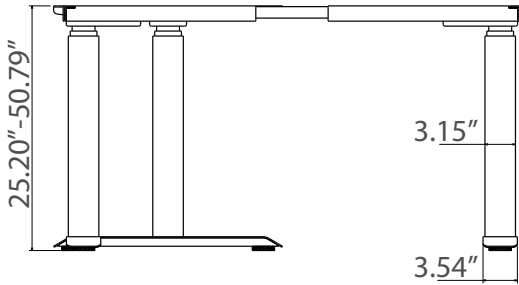

TYPE	DATA
Leg Shape	Square
Frame Height Adjustable Range	25.20" - 50.79" (Top adds 1.1")
Frame Adjustable Range	$W(42.13-70.67")+(42.32-70.87")*D(23.62")$
Foot Length Size	23.62"
Speed	1.6" /second
Maximum Lifting Capacity	330 lbs
Input	100-240V