

OFD-C13ELBASE-A-

3 Stage, Dual Motor Electric Height Adjustable Base



(-BS) Brushed Silver



3 Memory Controller with 2 USB Ports

(Optional Casters)



Paint



Brushed Silver

White

Black

Available Dec 16!

Smart L-type Products
Automatic Lifting

Noise Level
45db

Warranty Period
7 years



RoHS

OFD-CI3ELBASE-A-

3 Stage, Dual Motor Electric Height Adjustable Base

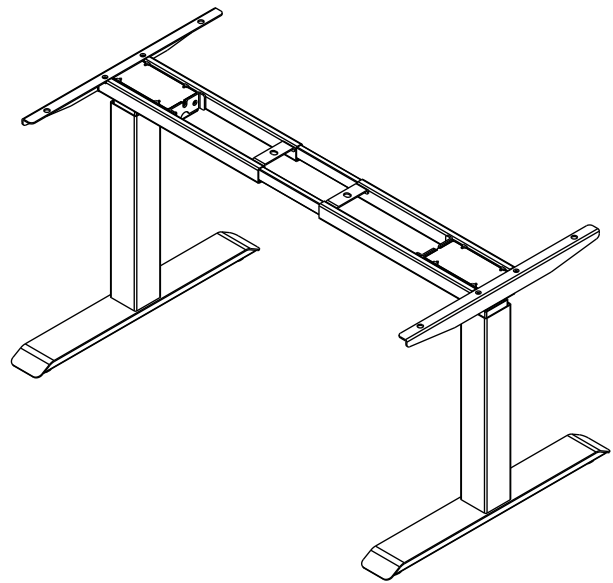
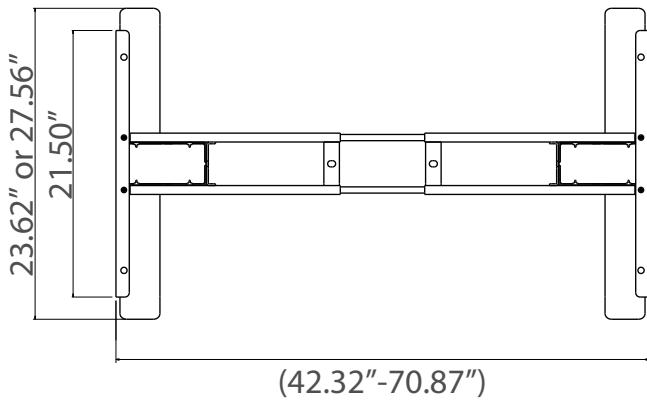
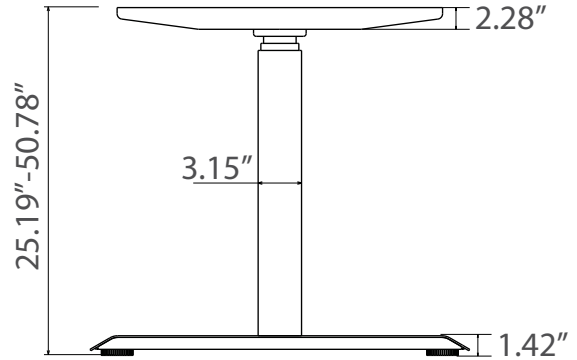
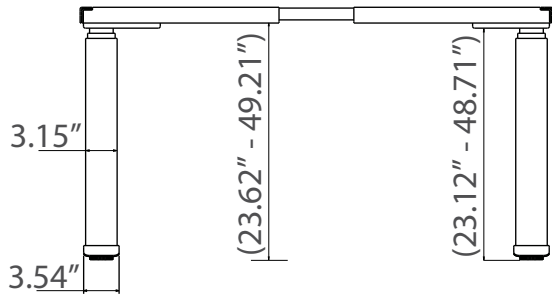

TYPE	DATA
Leg Shape	Square
Frame Height Adjustable Range	25.19" - 50.78" (Top adds 1.1")
Frame Adjustable Range	W(42.32-70.87")*D(21.5")
Foot Length Size (2 Options)	23.62" or 27.56" <i>Available Dec 16!</i>
Speed	1.6" /second
Maximum Lifting Capacity	264 lbs
Input	100-240V