

FL7484-U6

FAUX LEATHER VISITORS CHAIR

ASSEMBLY INSTRUCTIONS

STEP 1

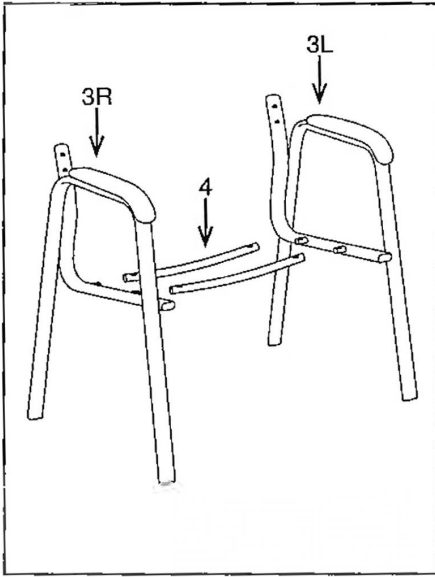

STEP 2

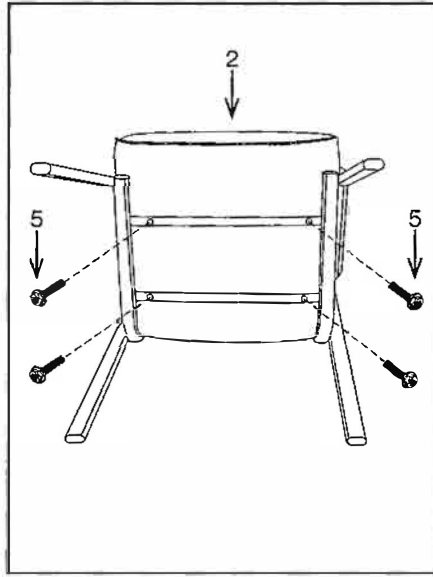

PART	QTY
1. Back Cushion	1
2. Seat Cushion	1
3. Frame (3L & 3R)	2
4. Support Bar	2
5. Bolt	8
6. Allen Wrench (not shown)	1

STEP 3

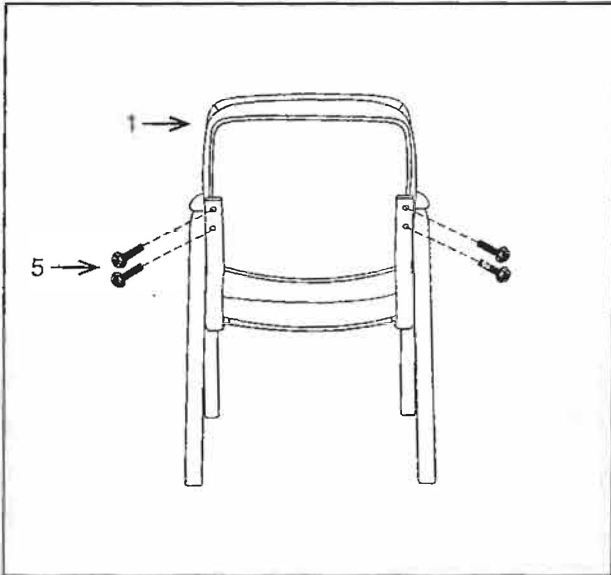

Remove all parts from carton, separate by part numbers indicated on parts list, and verify part quantities.

STEP 1 Attach two Support Bars (4) to Frames (3L & 3R).

STEP 2 Attach Seat Cushion (2) using four Bolts (5). **DO NOT FULLY TIGHTEN BOLTS.**

STEP 3 Attach Back Cushion (1) to Frames using four Bolts (5). **FULLY TIGHTEN ALL BOLTS.**

ATTENTION: MAKE SURE ALL BOLTS ARE FULLY TIGHTENED BEFORE USING CHAIR.